



AQA nano

Limescale protection

Effective limescale protection up to 20°dH and flow rates of up to 25 litres per minute

Important notice: Always keep the fitting and operating instructions close at hand to avoid any mistakes and before carrying out any work on the device you should read the fitting and operating in-structions carefully and follow them. While our data sheets and brochures should provide advice to the best of our knowledge, the content thereof is not legally binding. In addition to this, our general terms and conditions of trade apply.

Subject to alterations!

bwt.com



Fig. 1

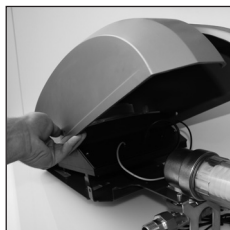

Fig. 2

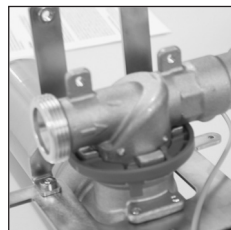

Fig. 3

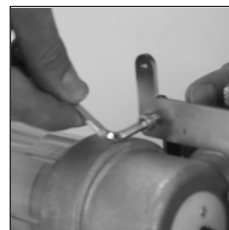

Fig. 4

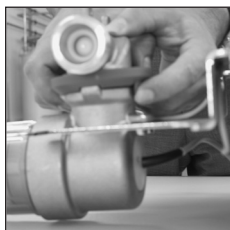

Fig. 5



Fig. 6

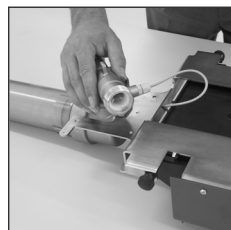

Fig. 7

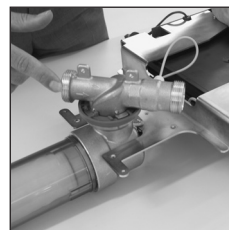

Fig. 8



Fig. 9



Fig. 10



Fig. 11

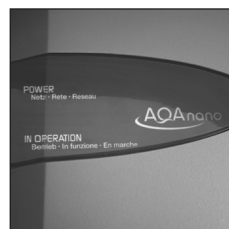

Fig. 12



Fig. 13



Fig. 14



Fig. 15



Fig. 16



Fig. 17

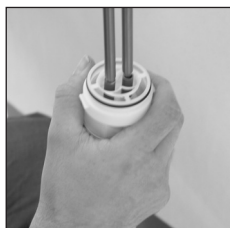

Fig. 18

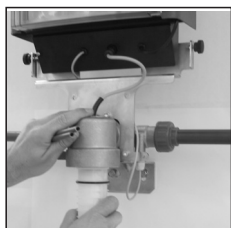

Fig. 19



Fig. 20

Dear Customer,
Thank you for purchasing the latest generation BWT limescale protection device. With the AQA nano you are getting value for money and entering into the world of the BWT nano-crystal technology and at the same time giving you and your family unique benefits:

- **BWT Comfort:** AQA nano is unmanned and you can rely on the electronics to remind you of the annual service required.
- **BWT Security:** Protection against extreme calcification, blocked pipes and unnecessary hygiene risks from deposits up to 20° total hardness.
- **BWT Drinking water guarantee:** You will still enjoy all the valuable and essential mineral nutrients like calcium and magnesium. Your drinking water stays as it is!
- **BWT Service guarantee:** Sit back and enjoy the good feeling of having a competent partner at your side. You can rely on the Aqua Service guarantee and service package of the European market leader.

Note:
Always keep the fitting and operating instructions close at hand to avoid any mistakes and before carrying out any work, read the fitting and operating instructions carefully and follow them.

1. Scope of delivery

AQA nano limescale protection

AQA nano comes complete with the recently developed limescale protection unit for forming nano-crystals, the latest integrated control unit and screw connections.

To make maintenance easier, we would recommend before and after the AQA nano limescale protection device, fitting a robust and reliable maintenance shut-off device.

2. Function & Use

Limescale protection

AQA nano works on the principle of nano-crystal formation. The integrated limescale protection unit consists of a three-dimensional electrode. Defined current/voltage pulses cause a local displacement of the limescale carbonic acid balance in the water, causing so-called nano-crystals to be formed. Because of their small size,

the nano-crystals carry an electrical charge that prevents adherence. The nano-crystals as a whole are able to absorb the limescale in the water and thus prevent deposits in pipe work and boilers. The drinking water remains unaffected.

Application

AQA nano is used for limescale protection and thus for the prevention of limescale stains in pipes carrying drinking water up to 20°dH and in the downstream, closed water heaters up to 80°C (surface temperature). The processing of other media as drinking water for human consumption and use outside the flow limits of 25 l/min is not intended and shall lead to the loss of any liability claims against the manufacturer. Any prerequisites for fitting, limits of use, local installation regulations, general guidelines (e.g. DIN, VDE, DVGW, ÖVGW, SVGW, WWU, EVU,...), general hygiene requirements and technical data shall be adhered to.

The installation area must be frost-proof and protection of the device against heat sources over 40°C and chemicals of any type must be guaranteed. In terms of the composition of drinking water, the EU Directive 98/83 shall apply. Likewise, the WHO Drinking Water Standards and the Drinking Water Ordinance shall apply.

3. Pre-requisites for fitting

Local installation regulations, general guidelines, general hygiene requirements and technical data shall be followed.

The installation area must be frost-proof and guarantee the protection of the system against chemicals, dyes, solvents, vapours and environmental influences. The ambient temperature must not exceed 40°C. Protect the device from direct sunlight and ultra-violet light.

The area from the water meter to 1 m after the AQA nano device shall have a corrosion-resistant finish.

To protect the device from foreign particles, it is essential to add a DIN/DVGW (or ÖVGW) tested drinking water filter.

To protect the whole installation and the system, a pressure reducer should be added at a mains pressure greater than 4 bar.

A testing line is required for the function check of the AQA nano.

This can be done simply with 2 HM-extensions (= 244 mm) in the HydroMODUL system.

4. Fitting

Make sure that there is a sheltered socket in the installation area. The length of the connection cable of the device is 1 metre.

I. Unpacking the device

Remove the device from its packaging and check the delivery to see that everything is there and for any damage caused during transport.

II. Flow direction

Please note the desired flow direction prior to assembly. The device comes as standard with a flow direction "from left to right". If you need to change the flow direction, then proceed as follows:

- Remove the device cladding after releasing the two locking screws (knurled screws) on the side of the device (see Fig. 1 und 2).
- Set the device down with its back facing up on a soft base (see Fig. 3).
- Release the assembly bracket and remove it (see Fig. 4).
- To release the connector, press the circlip on both flaps together and pull it in the direction of the connection (see Fig. 5).
- Turn the connection 45° anticlockwise and remove it (see Fig. 6).
- Turn the base in the flow direction and re-connect it to the device (see Fig. 7, 8, 9).
- In so doing, please note the flow direction arrows and make sure the circlip clicks in. If the AQA nano is to be fitted in a vertical pipe, only turn the connector 45°. Then this is fitted again and secured.
- Then fit the support bracket back to its original position.

III. Connecting to the water pipe

Connect the device using the screw connection supplied to the pipe, and using the fastening bracket, screws and dowels supplied, to the wall. The projection of the tubular axle in AQA nano may be between 80 mm and 100 mm. The minimum ground clearance of the tubular axle or the assembly point in vertical pipes is 500 mm. After preparing the pipe, fit the wall bracket and set the device on the wall bracket.

The two screws connect your AQA nano limescale protection device to the wall bracket (see Fig. 10 and 11).

5. Start-up

After the installation or after changing the limescale protection unit, open the shut-off valve in front of the AQA nano limescale protection system and pressurize the device. Then check that all connections are properly sealed.

Important!

AQA nano and the integrated limescale protection unit are supplied dry for hygienic reasons. For this reason, we recommend thoroughly rinsing the device on start-up by opening a drain valve for approx. three minutes. This also allows any shavings and other impurities introduced on installation to be rinsed out.

Then put the mains cable into the protective contact socket provided and check that the two green indicator LEDs are working in the inspection window. Both indicator lamps must light up. When water is removed, the upper indicator LED starts to flash every two seconds. If this signal is not displayed, then check the flow direction, the power supply and the cable connections.

The device is now ready for use!

6. Operation

AQA nano displays all operating conditions through the two indicator LEDs in the inspection window (see Fig. 12).

When water is removed, the upper indicator lamp flashes every two seconds. If the indicator LED "IN OPERATION" goes out, then the limescale protection unit, as described in Item 7, must be changed. If the indicator lamp "POWER" goes out, there is either a fault in the power supply or the device has been seriously damaged. If the indicator lamp "POWER" does not flash when water is removed, then the water is not removed by the device or there is a fault in the device. In this case, please contact your fitter or your BWT technical advisor.

	POWER	IN OPERATION
Stand- By (both LEDs light up)	●	●
Stand-By, Replace limescale protection unit	●	○
Water removal (POWER flashes)	((●))	●
Water removal, remove limescale protection unit	((●))	○
No power supply or electrical fault	○	○

7. Changing the limescale protection unit

As soon as the indicator LED "IN OPERATION" goes out, the limescale protection unit must be changed.

- Isolate the water pipe before and after AQA nano and release the locking screws at the side of the device (see Fig. 13).
- Remove the device cladding.
- By opening the black drain screw at the bottom of the transparent cylinder, you can carry out the pressure discharge (see Fig. 14).
- Unscrew the transparent cylinder then manually (see Fig. 15).
- Now detach the limescale protection unit (see Fig. 16). You can, without any hesitation, put the limescale protection unit in the domestic waste or send it to be recycled.
- Open the protective covering of the new limescale protection unit and remove it from the packaging using the hygiene gloves supplied (see Fig. 17).
- Now set the limescale protection unit on the two titanium electrodes in such a way that the points of the electrodes stick into the two conduits of the limescale protection unit (see Fig. 18).
- Now push the limescale protection unit until it clicks over the electrodes (see Fig. 19).
- Now tighten the transparent cylinder again manually.
- Now confirm that the limescale protection unit has been changed, by holding the "RESET" key for around three seconds (see Fig. 20). The green indicator light "IN OPERATION"

now lights up again.

- Finally check that all cable connections are tight and fit the device cladding using the two locking screws.

8. Inspection

To guarantee the best level of hygiene safety, efficient working and long life for the device, we would recommend you carry out a regular visual check of the device (at least once a week) and check the operating status (LED lights). Professional maintenance / servicing by your expert fitter or our BWT customer service also provide the highest safety levels.

9. Operator duties

Although you have purchased a durable and easy to maintain product, every technical system requires regular service to guarantee its correct operation. A precondition for the operation and any warranty and guarantee claims is the compliance with the specifications listed in these operating instructions. These specifications concern in particular:

- normal use of AQA nano
- the operation within the operation limits (s. technical data)
- correct fitting by the approved specialist company
- Regular tests being carried out
- Service- and maintenance work being carried out by your specialist fitter or the BWT customer service

Protect your rights and have all the service and maintenance work, and the replacement of spare and wear parts carried out solely by specialist personnel (installation company familiar with the device or BWT customer service). Make sure you use original BWT spare and wear parts - these will guarantee you reliability for many years! We would recommend entering into a service agreement with your fitter or the BWT customer service

10. Warranty

In the case of a breakdown during the warranty period, please contact your trade partner giving the device type (see technical data or name plate on the device), the installation company or BWT's customer service. The national statutory warranty provisions shall apply as amended.

12. Technical Data

		AQA nano
Connection nominal diameter	DN	25
Connection thread	outside thread	1"
Limescale protection up to max. 20°dH	m ³ /h max.	1.5
	l/min. max.	25
	l/min. min.	0,6
Limescale protection capacity	m ³ max.	110 ± 10*
	months max.	12
Operating pressure PN	bar	16
Temperature water inflow max.	°C	30
Temperature environment max.	°C	40
Temperature boiler max.	°C	80
Dimensions of device & connection dimensions:		
Width x height	mm	300 x 710
Fitting length (with screw connections)	mm	234
Clearance: Wall middle of pipe	mm	80 to 100
Weight	kg	ca. 11
Cable length	mm	1000
Mains connection	Volt/Hertz	230/50, 110/60 **
Electrical connected rating	Watt	5.5
Capacity stand-by operation	Watt	1.8
Energy consumption per m ³ water	kWh	0.018
Type of protection		IP 54
* depending on water quality		
** country-specific		

13. Technical Drawing

AQA nano

Flow direction left to right

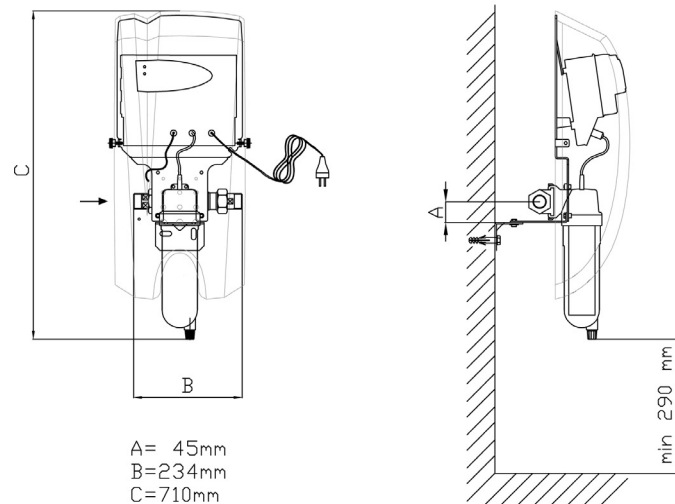

AQA nano

Flow direction right to left

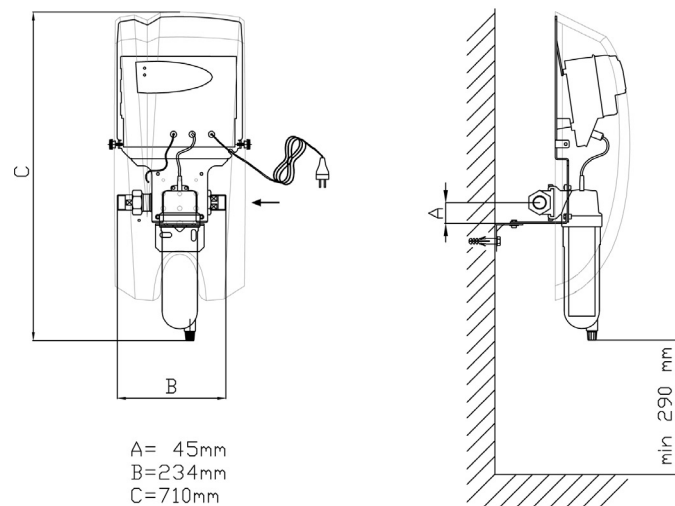



Contact Information:

BWT UK Limited

BWT House The Gateway Centre,

Cressex Business Park,

Coronation Rd, High Wycombe

HP12 3SU

E-Mail: enquiries@bwt-uk.co.uk Telephone: +44 (0)1494 838100