

UNDER-THE-SINK WATER FILTER

# AQA drink Pure LOFT

## MODERN KITCHEN AID THAT'S AN ABSOLUTE PLEASURE

### Filter cartridge

The AQA drink Magnesium Mineralized Water Protect filter cartridge, that comes with the set, is equipped with the patented BWT magnesium technology, which enriches tap water with Magnesium. Five filtration stages reduce substances such as chlorine, which can affect the smell and taste, and heavy metals, such as copper, lead and nickel. The filter also reliably removes limescale and therefore protects your household appliances.

### Tap

Via two levers you can choose, if you need filtered Magnesium Mineralized Water or normal, unfiltered hot or cold tap water. The separate water distribution system inside the tap is what makes this possible. A pull-out mousseur spray offers even more comfort when filling carafes or pots.

### Filter replacement indicator

The filter capacity is controlled by a programmable counter unit, which is connected through the flow sensor with the filter cartridge. You can program the capacity and runtime of the used filter. An acoustic signal indicates, when the filter cartridge must be changed.

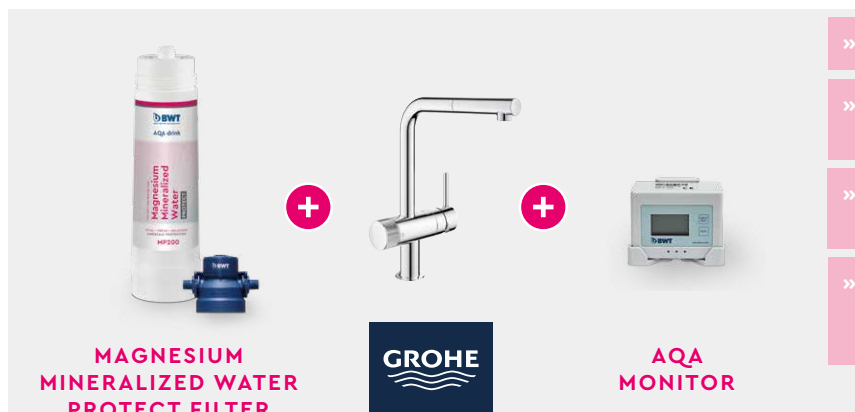
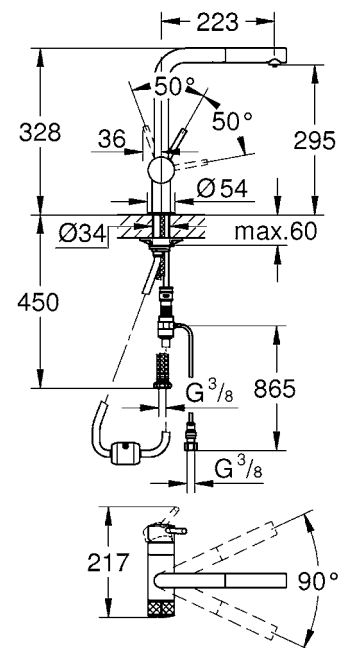

**MAGNESIUM  
MINERALIZED WATER  
PROTECT FILTER**



**AQA  
MONITOR**

- » COMPLETE SOLUTION
- » ONE TAP, TWO WATER OPTIONS
- » MAGNESIUM FILTER TECHNOLOGY
- » FILTER REPLACEMENT INDICATOR WITH ACOUSTIC SIGNAL

## OVERVIEW DATA

INFORMATION	SET
ARTICLE NUMBER	125252398
STYLE	L spout
TAP COLOUR	Chrome
TAP MATERIAL	Metal
ASSEMBLY	Single-hole assembly
Ø DRILL WORKTOP	34 mm
OPERATION	Swivel spout, single lever mixer and additional lever + pull-out mousseur spray
POWER CONNECTION	no
TAP HEIGHT	328 mm
TAP CONNECTORS	Braided hose with 3/8" swivel nut

## TECHNICAL DATA FILTER CARTRIDGE

INFORMATION	MP200
WORKING PRESSURE RANGE	2-8 bar
INTAKE WATER PRESSURE	>1.2 bar
WATER TEMPERATURE (MIN. - MAX.)	+4 to +30 °C
AMBIENT TEMPERATURE (MIN. - MAX.)	+4 to +40 °C
NOMINAL FLOW	180 l/h
OPERATING POSITION	horizontal/vertical
TOTAL HEIGHT WITH WALL MOUNTING BRACKET	385 mm
HEIGHT TO CENTRE OF CONNECTION	306 mm
Ø FILTER CARTRIDGE	88 mm

## FILTER CAPACITY\*

WATER QUALITY	TOTAL HARDNESS IN °dH*	BYPASS SETTING**	MP200
SOFT	<8	3	900 l
MEDIUM	8-14	3	470 l
HARD	15-21	2	280 l
VERY HARD	22-28	2	160 l
VERY, VERY HARD	>28	2	140 l

## TECHNICAL DATA AQA MONITOR

INFORMATION	AQA MONITOR
CONNECTION THREAD (IN/OUT)	3/8" nut x 3/8" connection thread
INTAKE PRESSURE (MIN/MAX)	2-8 bar
FLOW CAPACITY	0.8-15 l/min
DIMENSIONS (L x W x H)	80 x 47 x 30 mm
INSTALLATION POSITION	horizontal

\* The indicated filter capacity is valid for standardised lab conditions. In operation the capacity can vary due to different parameters. Replace the filter cartridge when capacity is exhausted, the flow rate noticeably decreases and at least every 12 months.  
°dH German Hardness

\*\* To adjust on filter head



**BWT UK Limited**

BWT House, The Gateway Centre, Coronation Road,  
High Wycombe, Buckinghamshire. HP12 3SU

☎ 04194 838 100  
✉ enquiries@bwt-uk.co.uk

*bwt.com*