

BWT bestcare 10



The Germ Catcher PLUS

OPTIMAL PROTECTION FOR ALL COLD WATER SYSTEMS WITH THE UNIQUE BWT GERM CATCHER PLUS WITH TRIPLE ACTIVATED CARBON BARRIER

The high quality of drinking water in Europe is ensured by legal regulations and the regular inspection of waterworks. However, even good drinking water can be affected by unforeseen problems such as the sudden entry of particles, cloudiness, bacteria and protozoa (e.g. Giardia and Cryptosporidium).

These issues can be caused by the public pipeline network or the installations in the affected building. Thanks to its newly developed triple activated carbon barrier, almost all particles, cloudiness and organic components can be safely reduced and unpleasant tastes and odours caused by chlorine and other substances can be reduced. The drinking results are perfected through the final BWT hollow-fibre membrane filtration to ensure the safe removal of bacteria and protozoa – with a very high dirt absorption capacity and low pressure loss.

Where can BWT bestcare 10 be used?

BWT bestcare 10 is the ideal solution for all water dispensers and drinking water systems, but it can also be used wherever cold water has to be safe to drink directly at the point of consumption.

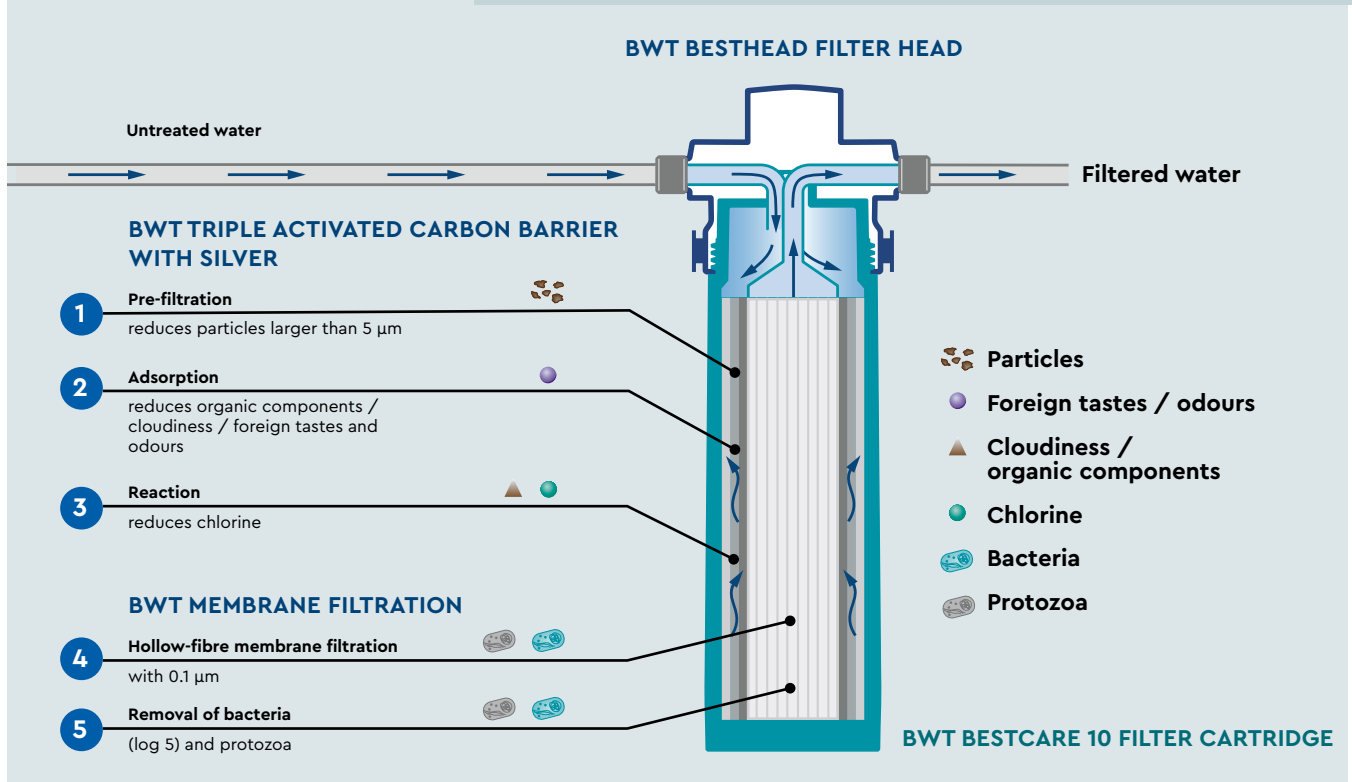

SPECIFICATIONS

Filter size	10
Maximum use [litres / months]	6,000 / 6 months
Nominal flow rate [l/h]	200
Pressure loss at nominal flow rate [bar]	0,8
Pore size of hollow-fibre membrane filtration [μm]	0,1
Flow pressure [bar]	> 1,2
Flush volume [litres]	1–3
Ambient temperature during transport / storage [$^{\circ}\text{C}$]	-20 – 40
Total height without bracket (A) in mm	287
Connection height (B) in mm	226
\varnothing filter cartridge (C) in mm	88
Weight in kg (dry/wet)	0,5/1,1
Order no. filter cartridge	125501411

Subject to change.

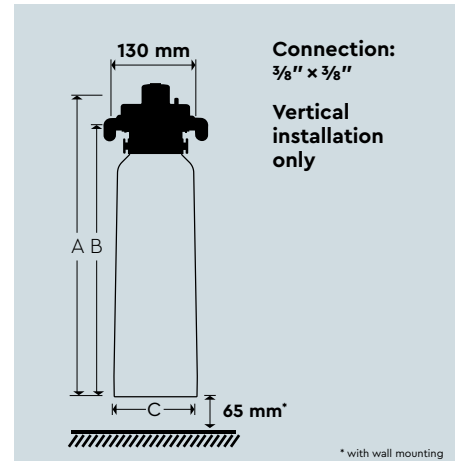

OPERATING CONDITIONS

Inlet pressure:	2–8 bar
Water temperature:	4–30 $^{\circ}\text{C}$
Ambient temperature:	4–40 $^{\circ}\text{C}$

BWT BESTCARE – THE GERM CATCHER PLUS

Main advantages

- Protection of downstream equipment such as drinking water dispensers
- Integrated BWT triple activated carbon barrier with silver
- Ideal for separation of particles, organic components and suspended solids
- Reduction of foreign taste and odour (chlorine)
- Perfect prevention against bacterial growth

Technical features

- Hollow-fibre membrane filtration (0,1 μm) with 99,999 % (log 5) retention of bacteria e.g. legionella and cysts
- Retention of microplastics
- Retention of particles by integrated prefiltration (5 μm)
- Silvered activated carbon to prevent bacterial growth
- Chlorine reduction >90% through integrated activated carbon filtration



ACCESSORIES

Description	Order number
BWT besthead FLEX filter head	FS00Z20A00
BWT besthead FLEX set 1	FS00Z39A00



ALTERNATIVE PRODUCT

Description	Order number
BWT bestcare MINI	FS10B00A00



MANUFACTURER:

BWT Holding GmbH:
Walter-Simmer-Str. 4
5310 Mondsee, Austria
BWT-WAM.COM

SALES:

BWT water+more
Deutschland GmbH:
info@water-and-more.de
Tel.: +49 611 58019-0

