

Operating instructions

# ES ECHO

- EN** Operating instructions
- FR** Mise en marche de votre robot nettoyeur de piscine
- DE** Bedienungsanleitung für den automatischen Bodensauger
- IT** Manuale di istruzioni
- ES** Funcionamiento del robot limpiador de piscina

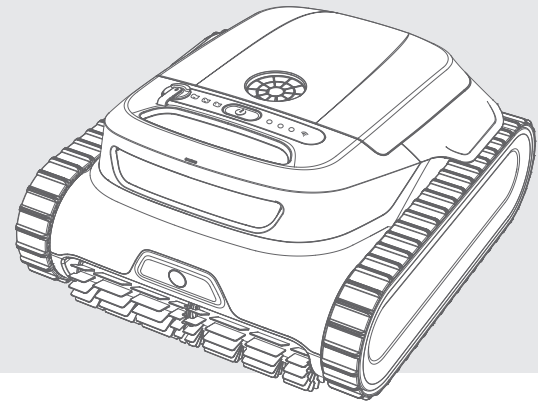

For full user manual please scan:

Pour le mode d'emploi complet, veuillez scanner

Für das vollständige Benutzerhandbuch scannen Sie bitte:

Para obtener el manual de usuario completo, escanee:

Per il manuale utente completo, scansionare:

Para obter o manual do usuário completo, digitalize:



## Warning

1. For your safety, DO NOT do anything other than the routine cleaning and maintenance as described in this manual. All parts must be replaced with original parts supplied by a BWT authorized service center.
2. USE ONLY the original battery and power adapter to charge.
3. DO NOT use if the power adapter is damaged. Before charging make sure that the connector and socket are dry and clean.
4. The power supply must be connected through a Ground Fault Current Interrupter (GFCI USA) or a Residual Current Device (RCD Europe) not exceeding 30 mA.
5. DO NOT attempt to charge the ES ECHO when the robot is running.
6. DO NOT ENTER the pool while the robot is running in the pool.
7. Improper installation and/or operation may void the warranty.
8. When it is charging, the robot should be kept in a cool place to avoid damage to internal electrical components caused by overheating.
9. This appliance can be used by children aged from 8 years and above and persons with reduced physical, sensory or mental capabilities or lack of experience and knowledge if they have been given supervision or instruction concerning use of the appliance in a safe way and understand the hazards involved. Children shall not play with the appliance. Cleaning and user maintenance shall not be made by children without supervision.
10. DO NOT attempt to replace the battery yourself. Contact customer service for assistance if the battery needs to be replaced.

### WARNING:

Use only with **DZ072CWL252250V / DZ072CWL252250U / DZ072CWL252250S / DZ072CWL252250B** battery charger.

**Read the manual and follow the instructions accordingly. In case of inappropriate use, BWT is not liable for losses or injuries.**

1. This device must be installed and operated as specified.
2. This device must be installed to provide a separation distance of at least 20cm from all persons and must not be colocated or operating in conjunction with any other antenna or transmitter.
3. Under Industry Canada/Europe/Australia regulations, this radio transmitter may only operate using an antenna of a type and maximum (or lesser) gain approved for the transmitter by Industry Canada/Europe/Australia.
4. Any changes or modifications not expressly approved by the party responsible for compliance could void the user's authority to operate the device.
5. When not in use, please store the device in a shaded area, away from direct sunshine or any heat source. (We recommend taking the device out of the water after each use).

## In The Box

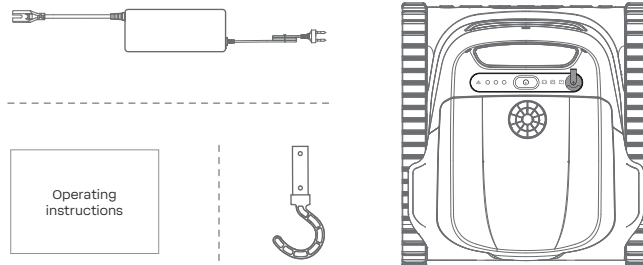

## Quick Setup

### Download the BWT Robotics App



### Register or Log In

1. Press the power button for 2 seconds to turn on the robot.
2. Download the BWT Robotics App in your app store.
3. Follow step-by-step instructions to set up your robot.

**Note:** Please turn on Bluetooth and enable location services so that your phone can detect the robot during the set up process (**Only support 2.4GHz Wi-Fi**).

### Reset Wi-Fi

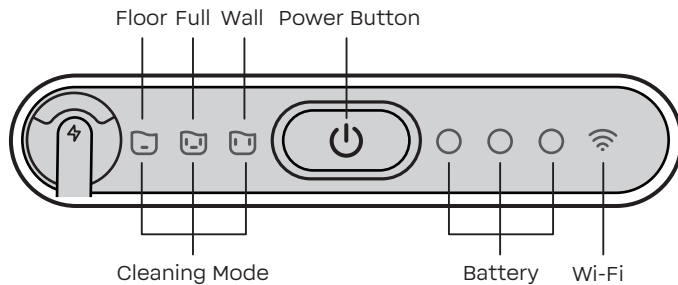

1. If the Wi-Fi indicator light is flashing, it means it is waiting to be paired.
2. If the Wi-Fi indicator light is solid on, it means it is already connected to a Wi-Fi network. To reset Wi-Fi, press and hold the power button for at least 8 seconds until the Wi-Fi indicator starts flashing again.

## Charging

1. Fully charge the robot for 5 hours prior to the first cleaning job.
2. To ensure battery safety, please keep the charging pins dry. You can wipe them with a dry, soft cloth. Before charging, please wipe away any water from the charging pins.

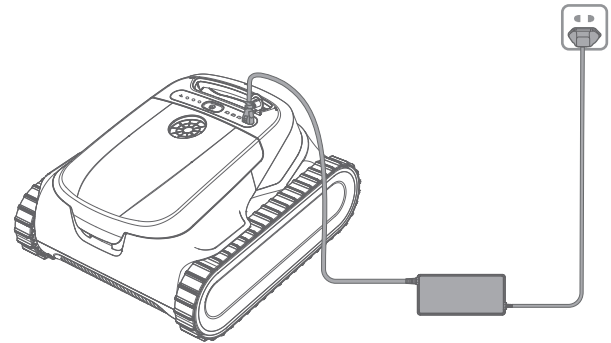



Battery	Status
● ● ●	67 ~ 100% Battery
● ● ○	34 ~ 66% Battery
● ○ ○	1 ~ 33% Battery
Flashing	Charging

## Operation

### Start Cleaning

1. Press the power button for 2 seconds to turn on the robot.
2. Tap the power button briefly to select the desired cleaning mode.
3. Once the mode light stays solid, place the robot into the pool within one minute to start the operation.

Icon	Meaning	
	<b>Floor</b>	Clean the pool floor
	<b>Full</b>	Clean the pool floor and walls
	<b>Wall</b>	Clean the pool walls and waterlines

## Auto Park

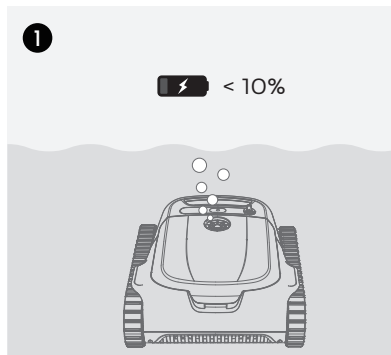

The robot will autopark **(move to the pool edge)** once it completes the cleaning or when the battery level < 10%.

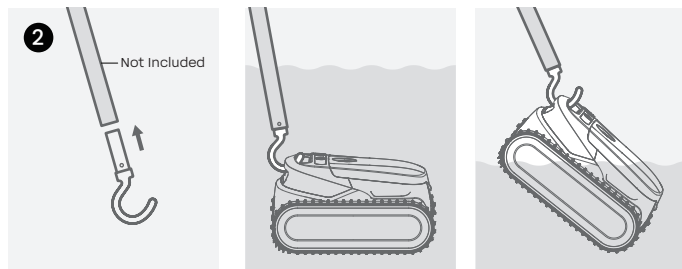

To remove the robot from the pool, attach a standard pole (**not included**) to the retrieval hook and use it to lift the robot out of the water.

## Auto Park

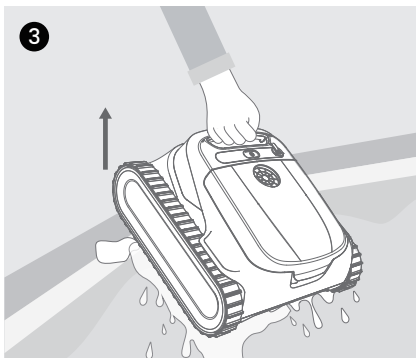

Hold the robot vertically to drain the water out.

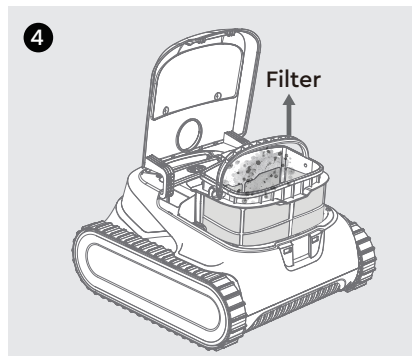

Open the filter cover and remove the filter from the robot.

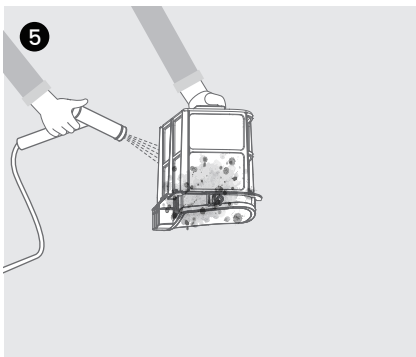

Empty all debris from the filter. Then rinse the filter using a hose with clean water. When it's too dirty, clean the filter with soapy water and a soft bristle brush.

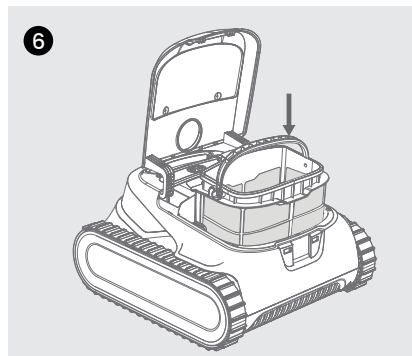

Install the filter in the robot and close the cover properly for your next cleaning. Put the robot in a dry place and let it dry properly. Do not put the robot under direct sunlight.

## Care and Maintenance

### Filter Basket (replace as needed)

1. Open the filter cover and remove the filter from the robot.
2. Insert the new filter.
3. Carefully close the filter cover.
4. It is recommended to clean the filter basket after each cleaning cycle.

### Impeller Cover (clean as needed)

1. Turn off the robot. Open the filter cover and remove the filter basket.
2. Rotate and remove the impeller cover, then use a small knife or another tool to clean any tangled hair.
3. Rotate the impeller cover back into place.

### Long-term Storage

1. Please charge the battery to at least 60 ~ 80% before long-term storage. Recommended storage temperature: -5 ~ 35°C (23 ~ 95°F). For optimal battery health, perform at least one charge every 6 months.
2. When not in use, please store the robot in a shaded area, away from direct sunshine or any heat source.

## Product Specification

<b>Product Dimension</b>	430 * 400 * 230 mm
<b>Item Weight</b>	7.8 kg
<b>Battery Capacity</b>	7,800 mAh
<b>Max Power</b>	100W
<b>Power Adapter Input</b>	100 ~ 240V AC 50/60 Hz
<b>Power Adapter Output</b>	25.2V DC
<b>Storage Temperature</b>	-5 ~ 35 °C
<b>Water Depth</b>	0.5 ~ 4 m
<b>Water Temperature</b>	5 ~ 35°C
<b>pH Level</b>	7.0 ~7.8
<b>NaCl</b>	Max 4,000 ppm
<b>Chlorine</b>	Max 4 ppm

## FCC Statement

This device complies with part 15 of the FCC Rules. Operation is subject to the following two conditions: (1) This device may not cause harmful interference, and (2) this device must accept any interference received, including interference that may cause undesired operation.

Any Changes or modifications not expressly approved by the party responsible for compliance could void the user's authority to operate the equipment.

This equipment has been tested and found to comply with the limits for a Class B digital device, pursuant to part 15 of the FCC Rules. These limits are designed to provide reasonable protection against harmful interference in a residential installation. This equipment generates uses and can radiate radio frequency energy and, if not installed and used in accordance with the instructions, may cause harmful interference to radio communications. However, there is no guarantee that interference will not occur in a particular installation. If this equipment does cause harmful interference to radio or television reception, which can be determined by turning the equipment off and on, the user is encouraged to try to correct the interference by one or more of the following measures:

- Reorient or relocate the receiving antenna.
- Increase the separation between the equipment and receiver.
- Connect the equipment into an outlet on a circuit different from that to which the receiver is connected.
- Consult the dealer or an experienced radio/TV technician for help.

## Canada Statement

### - English:

This device contains licence-exempt transmitter(s)/receiver(s) that comply with Innovation, Science and Economic Development Canada's licence-exempt RSS(s). Operation is subject to the following two conditions:

This device may not cause interference.

This device must accept any interference, including interference that may cause undesired operation of the device.

The antenna(s) used for this transmitter must be installed to provide a separation distance of at least 20 cm from all persons and must not be collocated or operating in conjunction with any other antenna or transmitter, End-Users must be provided with transmitter operation conditions for satisfying RF exposure compliance.

### - French:

Cet appareil contient des émetteurs/récepteurs exemptés de licence qui sont conformes aux flux RSS exemptés de licence de Innovation, Science et développement économique Canada. L'exploitation est soumise aux deux conditions suivantes:

Cet appareil ne doit pas causer d'interférences.

Ce dispositif doit accepter toute interférence, y compris toute interférence pouvant causer un fonctionnement indésirable du dispositif

Les antennes utilisées pour cet émetteur doivent être installées pour assurer une distance de séparation d'au moins 20 cm par rapport à toutes les personnes et ne doivent pas être localisées ou fonctionner conjointement avec d'autres antennes ou émetteurs. Les utilisateurs doivent avoir des conditions de fonctionnement de l'émetteur pour satisfaire à la conformité à l'exposition RF.



---

**BWT Holding GmbH**  
Walter-Simmer-Str. 4, 5310  
Mondsee, Austria