

# BWT bestdrink



## The companions

### BWT PREMIUM water – perfect mineralization with magnesium

BWT bestdrink PREMIUM is a filter system especially for the refinement of drinking water for enjoyment from drinking water dispensers. Thanks to the patented BWT Magnesium Technology, magnesium is added to the raw water in a targeted way, replacing the calcium. This mineralization in favour of magnesium gives the optimized water a very pleasant, slightly mineralized taste. Regardless of whether the water is chilled or not chilled, carbonated or still, mineralization with magnesium improves its sensory quality and turns all water into PREMIUM water.

In addition, the multi-stage filter reduces unwanted ingredients such as particles, organic components and chlorine. The filter system consists of a filter cartridge with a BWT besthead filter head screwed onto it. Check valves in the filter head prevent return flow and uncontrolled water escape. Food-safe BWT bestdrink PREMIUM filter systems are pressure-resistant and safe. They can be operated worldwide in any water dispensing unit.

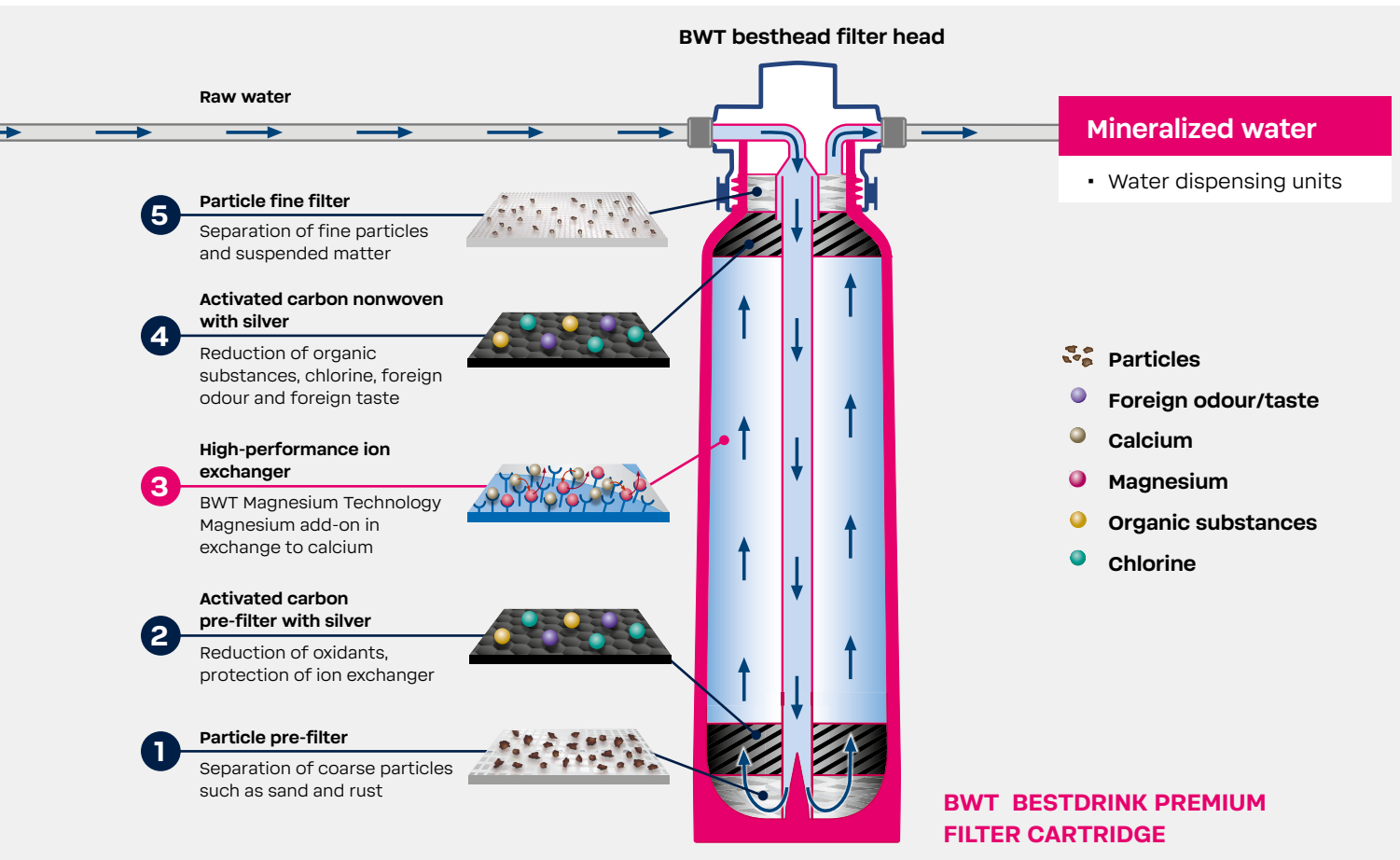

## TECHNICAL DATA

Filter size	S	V
Total height without bracket (A) in mm	368	429
Connection height (B) in mm	307	368
Ø filter cartridge (C) in mm	88	110
Weight in kg (dry/wet)	0,9/1,5	2,1/3,2
Filter change after month	after 6 or 12*	after 6 or 12*
<b>Order no. for filter cartridge</b>	<b>FS22100A00</b>	<b>FS23100A00</b>

\* Recommendation: Replace the filter cartridges regularly after 6 months, but at the latest after 12 months or when the filter capacity is reached.

## SETTINGS AND CAPACITIES<sup>(1)</sup> (no bypass setting)

Water dispenser (Only for use with cold water up to 30 °C)		
German total hardness	Size	
	S	V
4	5000	12500
5	4000	10000
6	3300	8330
7	2850	7140
8	2500	6250
9	2220	5550
<b>10</b>	<b>2000</b>	<b>5000</b>
11	1810	4540
12	1660	4160
13	1530	3840
<b>14</b>	<b>1420</b>	<b>3570</b>
15	1330	3330
16	1250	3120
17	1170	2940
18	1110	2770
19	1050	2630
20	1000	2500
21	950	2380
22	900	2270
23	870	2170
24	830	2080
25	800	2000

<sup>(1)</sup> Capacities may deviate by up to ±5% depending on the local water quality and volume flow. Not applicable for hot drinks, for those application we recommend BWT bestmax PREMIUM. Subject to change.

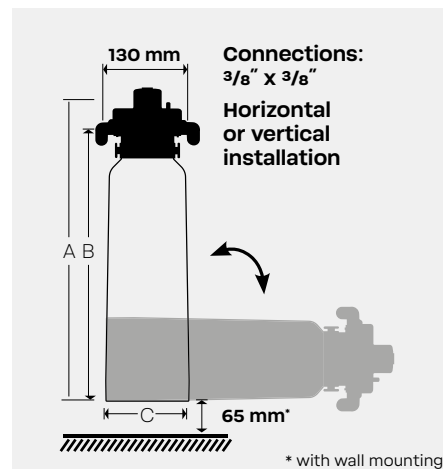

## Operating conditions

Input pressure: 2 – 8 bar  
 Water temperature: 4 – 30 °C  
 Ambient temperature: 4 – 40 °C

## ACCESSORIES

	Description	Order number
BWT besthead FLEX filter head	BWT besthead FLEX with 2 connectors 90° elbow, FLEX Insert, M 3/8" made from GFP	FS00Z20A00
BWT besthead FLEX Set 1	BWT besthead FLEX with 2 connectors 90° elbow, FLEX Insert, M 3/8" made from GFP, Connection hose DN 8, 1.5m, with ball valve, FLEX Insert 90° elbow made from GFP, cap nut FM 3/8", Connector straight, FLEX Insert x M 3/8" made from GFP, Reduction FM 3/4" x M 3/8" made from GFP	FS00Z39A00



## MANUFACTURER: SALES:

**BWT Holding GmbH:**  
 Walter-Simmer-Str. 4  
 5310 Mondsee, Austria  
 bwt-wam.com

**BWT water+more  
 Deutschland GmbH:**  
 info@water-and-more.de  
 Tel.: +49 611 58019-0